



TPW WOOLPRESS

Operator manual
for models
Aussie Xpress
&
Kiwi Xpress

Read before operating

Manufactured by

Heiniger

HEINIGER AUSTRALIA

Contents

1	General information
1.1	Introduction
1.2	Intended use
1.3	Contact addresses
2	Safety
2.1	Safety notice
2.2	Essential operator skills
2.3	Measures for avoiding accidents
3	Accepting delivery
4	Transporting
5	Guarantee
5.1	Introduction
5.2	Guarantee period
5.3	Conditions
6	Technical data
6.1	Dimensions
6.2	Electric
6.3	Petrol
6.4	Hydraulic system
6.5	Cycle time
6.6	Weighing system
7	Power supply & connections
8	Assembly
9	Jockey wheel
10	Woolpress operation
11	Weighing system
11.1	Scale operation
11.2	Weighing modes
11.3	System care
11.4	Span calibration procedure
11.5	Avoid overweight bales
11.6	Mechanical considerations
12	Woolpress maintenance
12.1	Safety guard maintenance
12.2	General maintenance
12.3	Daily maintenance
12.4	Monthly maintenance
12.5	Oil change
12.6	Filter change
12.7	Pressure relief valve
12.8	Control valve neutral adjustment
12.9	Baling pin adjustment
12.10	Unpinning clearance
12.11	Hydraulic pump operation
12.12	Pump adjustment procedure
13	Troubleshooting
14	General layout illustration
15	Side view
16	Lubrication points illustration
17	Warranty registration

1 General information

1.1 Introduction

This manual has been compiled to assist in the operation and maintenance of TPW Woolpresses.

HEINIGER Australia reserves the right to amend, add or delete any parts of these instructions of specification without notice.

*Note: As it is not possible to instruct a person to a competent level in the use of this woolpress from a manual alone, HEINIGER Australia asserts that the owner/manager of this woolpress must employ an operator who will be familiar with wool pressing in general and has an understanding of the process and some terminology or else will be instructed and/or supervised by a person with these requisites. Regardless of this the person operating this press must be able to read and understand this manual
If this is not the case then no attempt should be made to use this press.*

1.2 Intended use.

The TPW Woolpress is designed, manufactured and supplied for pressing wool. Other uses are expressly prohibited

The details in **6 Technical data**, count as mandatory operating limits and ratings.

1.3 Contact addresses

HEINIGER Australia

5A Tayet Link
Bibra Lake, Western Australia 6163
T: +61 8 9434 0000
F: +61 8 9434 0011
E: mail@heiniger.com.au
W: www.heiniger.com.au

HEINIGER New Zealand

1B Chinook Place
Hornby Christchurch
T: +64 3 349 8282
F: +64 3 349 8292
E: mail@heiniger.co.nz
W: www.heiniger.com

HEINIGER Australia

5 Devon Street
Lonsdale, SA 5163
T: +61 8 8326 0890

2 Safety

2.1 Safety Notice

HEINIGER Australia has fitted this woolpress with safety devices to help protect the operator during use. Should these safety devices become inoperable for any reason, it is the responsibility of the owner to ensure it is repaired before further use. All defects should be reported immediately to your supervisor.

It is an offence to operate this woolpress without the safety device fitted and in proper working order.

2.2 Essential operator skills

The owner/manager of this woolpress has an obligation to ensure that the operator is competent to use the press.

Operating the press safely only makes small demands of the operator. It is essential that they are observed and carried out.

The operator must have read and understood the manual or have been instructed in the operation of the press by a skilled person and have had the potential dangers pointed out to him. The operator shall be able to demonstrate an understanding of the press controls and the hazards associated with the press.

The continued effectiveness of the safety device shall be tested by the operator prior to the start of each shift of pressing, and at any time the operator has reason to suspect failure of any safety device component.

It is an offence to operate the press without the safety device fitted in proper working order.

2.3 Measures for avoiding accidents.

- Do not reach into any part of the woolpress while it is operating
- Store the woolpress in a dry undercover area when not in use
- Avoid getting electrical components of the woolpress wet
- Hang the power cable from the roof to avoid a tripping hazard and to avoid damaging the cord. Ensure the cord will not get caught in moving parts at the top of the woolpress
- After use disconnect the power
- Switch the woolpress off before disconnecting the power
- Never leave the woolpress unsupervised when connected to the power
- Avoid kinks and tight coils in the cable when storing, this can damage the cable
- The operating instructions must be kept safely and accessible to the operator at all times
- Do not wear loose clothing or jewellery when using this woolpress, tie back long hair
- The safe guards fitted to this woolpress must be kept in proper condition
- The safe guards must be fitted and operational before using this woolpress
- Children are not permitted to use the woolpress
- Children are not permitted in the vicinity of the woolpress when it is being operated or maintenance is being carried out
- Never use a damaged woolpress. Have the woolpress repaired by an authorized service agent or qualified technician
- Any damage to or failure of the woolpress which may constitute a risk to the health and safety of any person shall be immediately reported by the operator to the owner/manager who shall take appropriate action

Examples of the type of damage which would constitute such a risk include:

- Damage to any part of the woolpress
- Frayed or damage insulation on electrical wiring;
- Cracked, perished or damaged hydraulic hoses, pipes or fittings;
- Overheating of any motor or pump; or
- Failure or wear of any control or component.
- Damaged or loose fasteners, nuts, bolts, etc.

3 **Accepting delivery**

All units are transported at the owner's risk.

Before accepting delivery, thoroughly inspect the Woolpress for damage.

If any has occurred you should note the nature and extent of the damage in view of any insurance claim you may wish to make.

Whilst all care is taken during manufacture and by our agents to ensure your woolpress arrives in perfect working order and condition, damage occurring during transit or faulty operation resulting from damage occurring during transit will not be covered by our warranty.

The following areas should be checked carefully:

- Guide rods, including the return bolt and the adjustable pinning lug, these must be present and secure.
- The pinning guards. They should locate securely in place.
- Check scale components, indicator, cords and fittings.
- Electrical components etc (where fitted).
- Petrol Engine (when fitted).
- All ancillary equipment, i.e. panels, axles, wheels, jockey wheel, etc
- Hydraulics, Check for leakage at all connections and damage to hoses etc.
- Check fluid levels.
- Check that safety devices are operating correctly.
- Electric motor (where fitted) Fan cover etc.

4 **Transporting.**

The TPW Woolpress is supplied on transport skids. It is advisable to use the transport skids whenever practicable when transporting the woolpress.

Ensure that there is no load on the load cell or wheels and the hydraulic cylinder is lowered. A Woolpress Trolley is available, to enable easy movement from shed to shed. The trolley should only be used when it is safe to do so.

When moving the press with the transport skids fitted it is advisable to:

- Use only a forklift truck that is adequate for the task.
- Use only a driver qualified to operate the forklift truck.
- Only move over a stable, level surface.
- Lift only from the bottom of the woolpress between the transport skids and the base of the press.
- Lift only from the front or rear of the woolpress.
- Spread the forks as wide as possible within this space.
- Ensure that the woolpress is fully on the forks before lifting.
- Keep the woolpress as close to the ground as possible when moving.
- Move no faster than walking pace.
- Take care when turning corners and stopping as the woolpress may slide on the forks.
- Lower the woolpress gently.
- Only lower the woolpress onto a stable, level surface.

Because of the woolpresses height and centre of gravity when the hydraulic cylinder is in its operating position it can be unstable when being moved, for this reason it is advisable to fold the cylinder down when transporting.

Even when the cylinder is folded down care needs to be taken when transporting.

When the press is delivered from the factory the cylinder will be in the folded down position.

5 Guarantee

5.1 Introduction

HEINIGER Australia guarantee the "TPW Woolpress" manufactured by them to be free from defect in workmanship and materials. Their obligations pursuant to this guarantee are limited to the repair or replacement of parts and workmanship which prove defective within the specified period.

The repair or replacement shall be affected upon the defective equipment being returned freight pre-paid to the registered office of HEINIGER Australia or New Zealand or when authorised to the authorised Service Agents.

All travelling costs incurred by Service Agents performing repairs under warranty will be the owner's responsibility.

Where HEINIGER Australia supplies goods not manufactured by HEINIGER Australia, the customer shall only be entitled to such benefits as HEINIGER Australia may receive under guarantee as given to HEINIGER Australia by the manufacturer of those goods.

Some parts not covered by HEINIGER Australia

Hydraulic Cylinder, Hydraulic hoses, Electric motor, Hydraulic pump assembly, Hydraulic control valve, Starter switch, Scale components.

(These parts generally have to be sent back to the manufacturer for warranty inspection and assessment)

5.2 Guarantee period on parts manufactured by HEINIGER Australia

Primary producers: 25 months from the date of delivery.

Contractors: 12 months from the date of delivery.

5.3 Conditions

This guarantee will be invalidated for any of the following reasons:

1. If notice of the defect is not given to HEINIGER Australia or New Zealand within the guarantee period.
2. If the woolpress has been subject to misuse, abuse, negligence or accident.
3. If the woolpress is installed, maintained or operated in any manner other than that for which it is designed.
4. If the woolpress is used for any duty or subjected to any abnormal operating conditions varying from that for which it is supplied by HEINIGER Australia.

When making a warranty claim or ordering new parts, it is important that the serial number of the unit is quoted and the date of purchase stated.

6 Technical data

6.1 Dimensions

Height operational:	2705mm
Height shipping:	1970mm
Box height:	1185mm
Length:	1390mm
Width:	970mm
Weight:	530kg

6.2 Electric

Motor:	Teco Induction		
Electric:	4kw (5.5hp), 415V, 3Ø, 1440rpm		
Electric:	2.2kw (3hp), 240V or 480V at 1460rpm		
Electrical operating voltage and current:			
Nominal	Min Volts	Return stroke	Full load
Volts	Full load	Current	Current
240 V	220 V	11.0A	16.0A
480 V	440 V	6.0A	8.0A
415 V		8.0A	8.0A

6.3 Petrol

Engine: Honda 11 hp, Rope or Electric start.
Battery not supplied.
Remote power pack.

6.4 Hydraulic system

Oil capacity: 25 Litres
Oil type: Mobil DTE 24 or equivalent
Oil filter: Inline suction, 25 micron
Pump: Nachi PVS-IB-22 Variable displacement piston pump.
Discharge at 1460 rpm: 30 L/min @ 0-5 Mpa, and 7L/min @ 5-18 Mpa.
Control valve: Oilpath OP20 2000
Cylinder: G&R 88.9mm bore by 740mm stroke.
Pressure relief: 18,000kpa (2600psi)

6.5 Cycle time

	Empty	Full bale
With 240 V or 480 V:	12 seconds	16 seconds
With 220 V or 440 V:	13 seconds	20 seconds (low power supply)

6.6 Weighing system

Make: Iconix FX1+
Indication: LCD
Power supply: 12V DC
Load sensing: Single load cell
Zero facility: Automatic zero tracking or by zero facility.
Calibration: Factory calibrated
Memory: Will retain last shown weight indefinitely.
Range: 1.0 kg -750kg.

Specifications subject to change without notice.

Designed to comply with current Occupational Safety and Health regulations.

6.7 IP Rating

Product	IP Rating	Information	Contact
5.5kw cast frame TECO Motor	IP 56	TECO NZ	Mohammad TECO Technician Auckland
2.2kw cast frame TECO Motor	IP 44	TECO NZ	Mohammad TECO Technician Auckland
SS Switch + button	IP 65	NAW	Luke Sales Tech Melbourne
DOL Switch + button	IP 65	NAW	Luke Sales Tech Melbourne

7 Power supply & connections.

It is the responsibility of the owner to ensure correct power supply.

- The voltage specified on the electric motor manufacturers plate and that of the local power supply must match. The press motor may only be connected to an AC power supply.
- In the event that the press is operated from a generator, the mains supply voltage must not exceed that specified on the manufacturer's plate.
- Never plug the press into damaged sockets.
- Observe the relevant regulations applicable in your country.
- Completely unroll the power cable before plugging in.
- If a 3 phase motor is fitted the rotation must be checked prior to using the press. Correct rotation direction is indicated on the pump.

Note: Damage to woolpress components caused by incorrect power supply will not be covered by warranty.

8 Assembly

Note: Before assembling the woolpress ensure that there is adequate headroom for the woolpress. (see **6 Technical data**)

Note: DO NOT cycle the woolpress with an empty wool pack in the chamber, damage to the press and pack will occur.

Warning: Always ensure the control valve handle is in the neutral (centre) position before starting the motor.

For assembly of the woolpress, the following procedures must be carried out:

1. Note the IMPORTANT sticker on the press, which emphasises the need for the owners and operators to read the operators manual and to complete and return the warranty card.
2. Check the level of hydraulic oil (100mm from the top +/- 25mm) and crankcase oil level on petrol driven models.
3. Check the correct voltage is being supplied e.g. 240 volt or 480 volt. If 3 phase check motor rotation. If incorrect an electrician should reverse. If an extension lead must be used, it must be a 20 amp lead. Avoid leads longer than 10m.
4. Cut the cable ties that fasten the platen to the support bars, remove the nuts and washers from the cylinder mounting bolts.
5. With the control valve handle in the neutral or centre position, start the motor.
6. If the starter switch chatters and will not engage during start up, suspect low voltage power supply. An electrician should check the supply voltage under starting load and full load.

Warning: When using the hydraulics to raise the cylinder as described here, the motion of the cylinder does not appear consistent with the action of the handle, ie, when you pull the handle down the cylinder moves up. It is important to be aware of how the press will react to the movement of controls.

Warning: There is a pinch hazard between the flange plate of the cylinder and the top cross members of the press. Keep hands and fingers clear of the cylinder flange while raising the cylinder.

Warning: When raising the platen for the first time ensure that the top of the right hand guide rod does not get caught under the cylinder hydraulic hoses. If the guiderod is too close to the hoses, stop the platen and pull the hoses out of the way. The hoses must be restrained so that at no time can they get caught on the guide rod. If the guide rod does get caught on the hoses significant damage will occur to the woolpress. This damage will not be covered by warranty.

7. To extend the cylinder upward towards the crossbeam, ease the control valve handle down. Rotate the cylinder casing if necessary to align it with the mounting bolts. Keep hands clear of cylinder flange while raising the cylinder.
8. Stop the motor.
9. Fit the washers and nuts to the mounting bolts to **finger tight only**.

10. Start the motor and ease the control valve handle up to raise the platen until the unpinning post pins are level with the tips of the pawls when the pawls are held with the tip at its lowest possible point (see *illus at 12.10*). Stop the motor.
- Warning:** Do not attempt to hold any part of the press components (accept for the control valve handle) when raising the cylinder or platen.
11. Ensure that the gap between the tip of the pawl and the unpinning post pin is even on both sides. (see *illus at 12.10*)
 12. Tighten the mounting bolts & nuts securely. Remove the support bars from the press.
 13. Fit the load cell foot and remove the transport feet.
 14. Adjust the load cell foot so the press is level. Tighten the load cell foot lock nut against the load cell.
 15. Secure the jockey wheel in its catch and check to ensure that the jockey wheel brake foot is clear of the floor.
 16. Fit the indicator onto its bracket and plug the load cell lead into the indicator.
 17. With the press closed, plug the power supply in, then switch on using the **ON** key. The display should indicate zero, ▲. If not press **ZERO**. Applying weight to the press structure should register a reading.
 18. Before operating the wool press, lubricate all moving parts. When the bellcranks and baling pins are lubricated fit the pinning guards. (see *illus*)
 19. Start the woolpress and cycle it a few times to expel any air, which may be trapped in the hydraulic system.

9 Jockey Wheel

To use the Jockey Wheel pull it free of the catch and lower it towards the floor, this transfers the weight of the woolpress from the loadcell foot to the Jockey Wheel. The woolpress is now ready to move.

To use the brake foot lift the Jockey Wheel handle up about half way, retain a firm grip on the handle, when the brake foot contacts the ground it will stop the woolpress.

When the woolpress has come to a complete stop lift the Jockey Wheel up and push the plastic knob firmly into the catch to secure it.

Note: When pressing wool ensure that the Jockey Wheel is secured in the catch and the loadcell foot is fitted to the correct height so the brake foot on the Jockey Wheel is clear of the floor.

When moving the woolpress the loadcell foot must be clear of the floor.

When using the Jockey Wheel do not release it until it has been secured in the catch. If released, unrestrained upward movement can cause damage to the woolpress.

Do not allow any part of your body to come between the Jockey Wheel and the woolpress.

When moving the woolpress it is important that it has come to a complete stop before lowering the weight of the woolpress onto the loadcell foot.

The woolpress should not be used or moved on uneven, unstable or sloping surfaces.

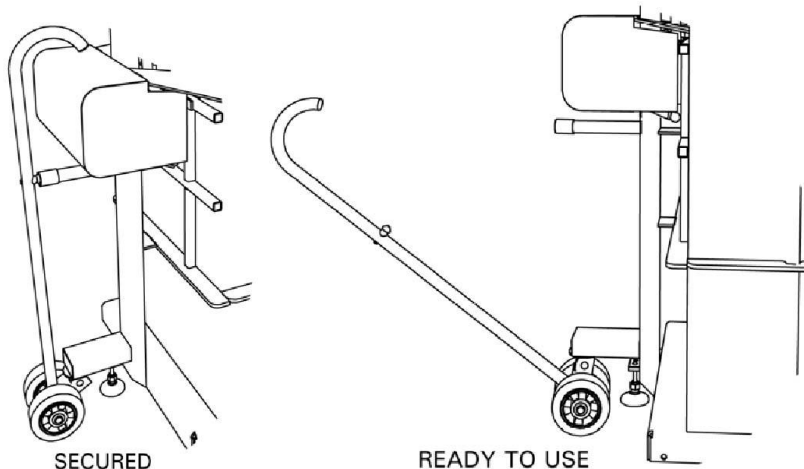

10 Jockey wheel illustration

Woolpress operation.

1. Close the rear door of the woolpress and secure with the locking bar handle.
2. Make sure the control valve handle is in the neutral position. Switch the press on.
3. With the hungry board and pack lock handle in the closed position turn the scales on and check that they are reading zero before proceeding.
4. Lift the pack lock handle and the hungry board. Hang the bale ejector belt over the front, centre of the bin and place the hook into the hook pocket, make sure that the pins in the packlock handle will not pierce the strap. The doubled over stitched part of the strap should be level with the bottom of the packlock when it is closed. Place a pack in the woolpress. Hang the flaps of the pack neatly over the four sides of the woolpress. The corner stitching should come to the top of the box. Close the hungry board firmly and secure with the pack lock handle.
5. Ensure that the hook on the hungry board is fitted over the locking bar handle, preventing the locking bar and door from being opened when the hungry board is closed.
6. Secure the pack lock handle with the pack lock clamp.
7. Fill the chamber to its maximum with wool. Pull the guard down. This will allow you to pull the control valve handle into the down position. The control valve handle will not operate down with the guard up. Then pull the control valve handle into the down position.
8. On the first pressing only, allow the platen to come down until just before the pins come in, push the control valve handle to the up position to return the platen to the top of it's stroke. If needed lift the guard.
9. After the first pressing, load more wool pull the control valve handle down and allow the press to complete its cycle without interruption. When the platen is returning it will automatically lift the guard.

Note: *If the pressing chamber of the press is not full of wool when the press is cycled the pack may get pushed into the chamber by the baling pins. If this happens it is possible for damage to occur to the pack and press.*

Note: *Always allow the press to complete a cycle. If a cycle is interrupted when the press is next cycled damage may occur due to the press being out of sequence.*

Warning: *When the press commences a cycle all parts of the operators body must be clear of the pressing chamber.*

10. During the pressing cycle the operator can get more wool. Continue compressing the wool until the desired weight has been achieved. HEINIGER recommends 190 -195 Kg
11. Closing off pack. On achieving desired bale weight allow the press to finish the cycle, while the pins are still in, spread wool evenly by pulling it from the centre of the bale and placing it to the sides of the press, cycle the press again to re-pin.
12. Open the pack lock clamp and pack lock handle and lift the hungry board, fold the left flap over the right flap and secure firmly with 3 bale fasteners, then fold the back flap over the front flap and secure with 4 bale fasteners. (The firmer the flaps -the neater the bale.)
13. Bale ejection. Close the hungry board and pack lock clamp. Pull the guard down. Pull the control valve handle down; as the platen descends, the bale pins will automatically withdraw. Allow the platen to continue downwards until the yellow mark on the right hand guide rod lines up with the yellow line on the cylinder.
14. Push the control valve handle into the middle/neutral position to stop platen movement.
15. Lift up the guard and open the pack lock and hungry board.
16. Attach the bale ejector belt hook to the bale ejector catch. Then open the back door.
17. Push the control valve handle up to raise the platen, thus completing the operation and ejecting the bale through the rear door.

See warnings & notes.

Warning: Do not attempt to eject a bale without first opening the door, substantial damage to the press will occur otherwise.

18. Disconnect the bale ejector belt from the bale ejector catch. The platen may have to be lowered slightly to do this. Ensure that the bale ejector belt is placed over the front of the pressing chamber.

19. Close the rear door of the woolpress and secure with the locking handle.

Note: Ejection from the rear of the press is possible by attaching the bale ejector belt from the front, move to the rear of the press with a woolbale trolley. Send the hydraulic ram upwards by pulling **down** on the yellow handle on the rear of the control valve linkage, thereby ejecting the bale onto the trolley. Take care not to over balance and get caught under the ejecting bale and trolley.

Note: If the bale ejector belt is not placed over the front of the pressing chamber prior to pressing a bale, the bale will have to be uninned and the wool removed by hand.

Note: If the guard is lifted during operation it will cause the platen to ascend.

The press will not operate in its down cycle with the guard raised or the hungry board open.

Ensure that the ejection catch is stowed on top of the platen when not in use.

11 Weighing system

11.1 Scale operation

1. Plug the power supply and the load cell into the indicator.
2. Press the ON key. The scale will automatically show zero unless weight has been left on the scale. The ZERO pointer ▲ will show that the scale is at zero.
3. If the scale does not show zero, press ZERO.

11.2 Weighing modes

Free mode: Normal weighing mode for woolpresses, Free mode is automatically selected at switch on. The display is continuously updated with the weight currently on the scale.

Hold mode: Hold mode uses an averaging process, which displays the accurate weight of a moving animal. The weight is locked on the display until the next key press.

11.3 System care

Fit caps to indicator sockets when not in use to protect from dirt and moisture. Hang the cable ends up out of mud and dust.

Damage may occur if the capacity of the scale is exceeded.

All cables must be kept in good condition.

11.4 Span calibration procedure

Note: The span calibration is performed independently for each scale type.

Note: To ensure that scale accuracy is maintained, the bale used to calibrate the scales should be as close to the maximum bale weight as possible.

Note: Start with the indicator turned off.

1. Plug the power supply and load cell into the indicator. Remove all live loads from the press.
2. Turn **ON**
3. SCAL2 will display
4. Wait for a number to appear then press **SETUP** then right across arrow and ensure the below are set. Use up arrow to change.
HOLD – up arrow to change to FREE
StAt.0
ZEr0.1
rEL5.0
bEEP.1
5. Right arrow across until SAVED is displayed.
6. Wait for a number to appear then press **ZERO**

7. Add weight
8. Press **SETUP**
9. Wait for D to display (this indicates woolpress mode)
10. Press **SETUP – ZERO – DELETE – WEIGH**
11. EnGL will display (this indicates the language will be English, to change use the up arrow)
12. Press the right arrow twice to display CAL (calibration)
13. Press **WEIGH**
14. SURE will then display
15. Press **WEIGH** again
16. CAL will display then a weight
17. Use the up and down arrows to change the weight to reflect the weight added
18. Press **WEIGH** when at the correct weight
19. SAVED will display and they are ready to use

Note: Having completed the span procedure the scales should be switched off then on and checked to confirm accuracy.

11.5 Avoid Overweight Bales.

Heiniger recommends that bale weights are checked for accuracy by using another set of scales, which are known to be accurate.

The woolpress must be used on a stable, level surface. Any movement in the floor will affect the performance of the scales.

Keep obstructions free of the press, make sure there is no build up of wool around or under the press.

Do not move the press halfway through a bale as the zero reference may not be the same. Ensure scale is on zero each time before putting the pack in.

If you press the **ON/ZERO** key when you already have the pack in, make sure you allow 2kg for the weight of the pack.

Bale weights.

Because of weight gains due to dampness or humidity, it is suggested to press bales only to 190/195kg so that bales do not exceed 204kg.

11.6 Mechanical considerations.

The following are the requirements, which are necessary for the electronic scales to perform as they are intended. These points can be causes of weighing problems. The zero facility is provided to reset the zero although this should not normally be necessary.

- *A firm, level floor surface is required*
- *Do not move the press around the floor during a bale as this will upset the zero reference point. If moving is necessary, wait until that bale is completed.*
- *Begin and end the bales with the press in the same condition i.e. if the scale is on zero and the press is ready to operate, (Door and hungry board closed, platen up etc.), the scale will not zero until the press is in the same condition.*
- *Check that there is not a build up of wool around the base of the press as this will restrict free movement.*
- *Check that the two bolts mounting the load cell are tight.*
- *Check that the press is level and lock nut on the load cell foot is tight.*
- *During operation the jockey wheel must be secured by the catch. The jockey wheel brake foot must be clear of the floor. If not it will effect the scale operation causing bale weights to be inaccurate.*
- *When moving the woolpress it is important that it has come to a complete stop before lowering the weight of the woolpress onto the loadcell foot, otherwise damage may occur to the loadcell and foot.*

12 Woolpress maintenance

12.1 Safety guard maintenance

The press is fitted with an interlocked safety device and guards to protect the operator during use. These must be maintained for safe/correct operation.

Before each shift starts the following parts must be checked for correct operation.

Safety guard	Safety guard linkage
Valve handle	Gas lifting strut
Safety guard arms	Pinning guards
Hungry board interlock assembly	Valve linkage

These parts are integral to the safe operating of the press. If they become damaged, worn or loose they must be repaired or replaced before using the press.

When replacing parts use only genuine replacements or parts that have the same specification.

The following checks must be carried out:

Note: *Turn the power off and leave it off while checking the operation of the safety device.*

1. With the safety guard open ensure that the valve handle cannot be pulled into the down position. If it can, repair or adjust before using the press.
2. Close the safety guard, pull the valve handle into the down position. Slowly lift the guard open. The valve handle should be knocked into neutral or the up position within approximately 25mm (1") of upward movement of the safety guard. If it does not, repair or adjust before using the press.
3. Open the hungry board, close the pack lock and the safety guard. Attempt to pull the valve handle into the down position. The valve handle should not be able to move into the down position. If it can, repair or adjust before using the press.
4. Check the security of the pinning guards, the pinning guards are routinely removed for maintenance. They must be replaced securely before the press is used.

12.2 General maintenance

Ensure the motor is switched off and the power disconnected while performing maintenance.

Always contact an authorized service centre if you are unsure how to rectify problems and in the event of a malfunction not contained in this manual.

Maintenance instructions listed here are guide lines only, because of differing conditions that presses experience it is impossible to say what maintenance a press will need and when.

Note: *If any parts are replaced on the press, use genuine replacement parts or ensure that replacement parts have the same specification as the old parts.*

12.3 Daily maintenance. (8 to 10 hrs of operation)

- Grease/oil the locking bar, rotate and lift the locking bar for better access. Use a good quality general purpose grease and good quality engine oil.
- Check correct operation and adjustment of safety device.
- Check the security of the platen retaining bolt that secures the platen to the cylinder rod.

Note: *If the press is allowed to operate with this bolt not properly secured the hydraulic circuit will be placed under undue stress that will prematurely wear components.*

12.4 Monthly maintenance. (200 hrs of operation)

- Grease both guiderods and grease/oil all moving parts.
- Check the accuracy of the scales. Check the weight of the most recently pressed bale on scales known to be accurate.
- Check the security of the cylinder retaining nuts and platen retaining bolt.
- Check the security of all other fasteners. Some fasteners secure hinging parts, do not over tighten these fasteners. Hinging parts need to move freely through the range of movement without being loose.
- Check the hydraulic oil level and replenish as necessary. Use specified oil.

- The hydraulic oil level is checked with the platen in the up position. To check, remove the filler/breather cap on the tank. The oil should be approximately 100mm from the top +/- 25mm.
- Oil the bellcrank assembly and baling pin bosses, remove the pinning guard to do so. Apply oil to all moving joints, wipe off excess. The bellcranks can be moved in and out by hand.
- Check the security of the circlips retaining all pins.
- Check the adjustment of the baling pins.
- Clear any wool from inside the pinning guards.

Note: Failure to perform reasonable maintenance on the press will result in premature wear or damage to the press. This wear or damage is not covered by the manufacturer's warranty.

12.5 Oil change

Change the oil every 12000 hours of operation. This is an approximate figure. If the oil is contaminated by water or foreign matter, or has been overheated then the oil will need changing more frequently.

12.6 Filter change

Change the oil filter and tank filler/breather cap every 2000 hours of operation. This is an approximate figure. If the press is operating in a very dusty or humid environment the filters will need changing more frequently.

Note: If any parts are replaced on the press, use genuine replacement parts or ensure that replacement parts have the same specification as the old parts.

12.7 Pressure relief valve

Situated on the control valve (see illustration). The pressure in this valve is factory set to 18,000 KpA(2600 psi) and should NOT be adjusted. Occasionally, this valve may be heard to squeal when the press has returned to neutral. This is caused by the spool not centralising, either through the detent on the bottom of the spool becoming loose, or the valve trip lever not operating correctly.

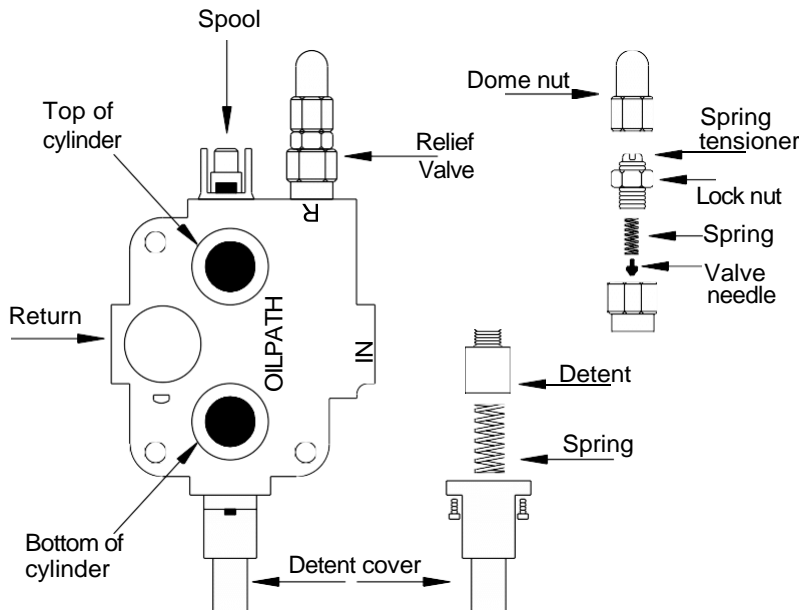

Control valve illustration

12.8 Control valve neutral adjustment

Due to normal running in of new components it is sometimes necessary to adjust the control valve neutral rod, to ensure that the control valve will automatically return to neutral at the completion of its cycle.

Adjustment

Should the valve not drop into neutral, tap the control valve neutral rod to the right or left until correct action is achieved. Several cycles of the press may be required for this setting. If the adjustment is moved too far to the left (rear view), or too close to the pivot bolt, the valve may push too far and go over 'centre' and cause the ram to re-cycle automatically.

This adjustment may require setting from time to time as the press settles in.

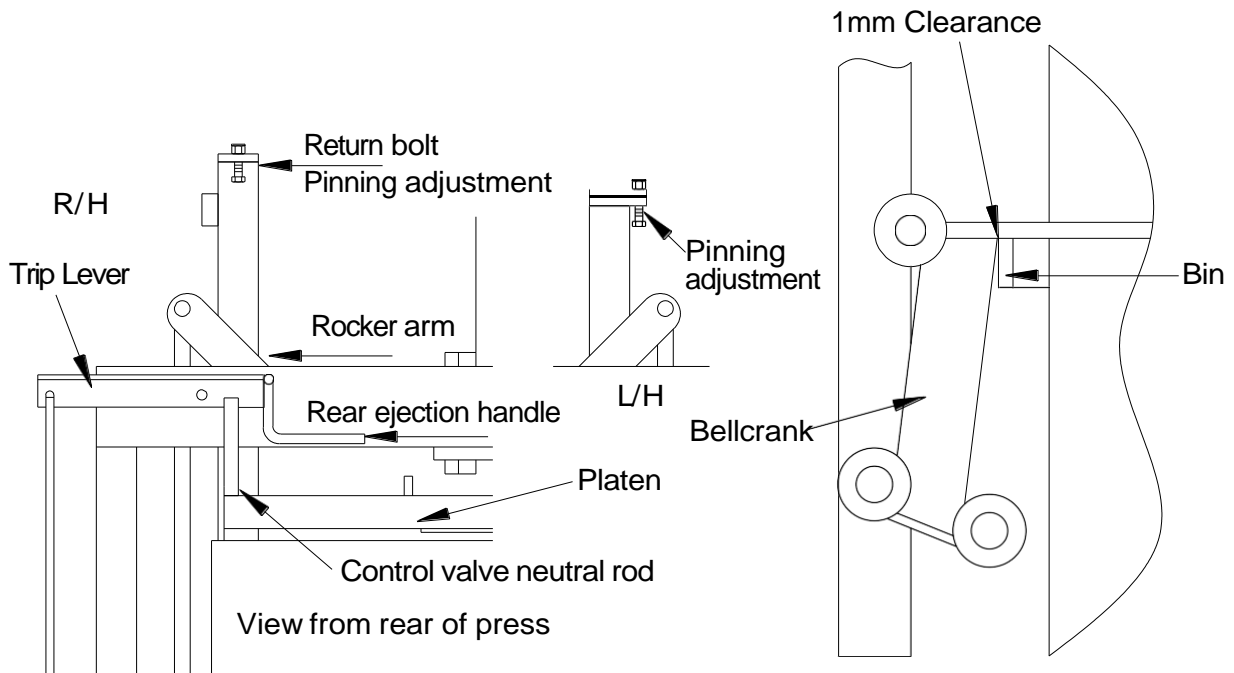

Control valve neutral adjustment illustration

12.9 Baling pin adjustment

When the guide rods are at the maximum down position, the pins are correctly set if there is approximately 1mm of backlash.

To set the Baling pins:

Note: If the left hand bank of pins has less backlash than the right hand it is advisable to back off (wind up) the adjustment bolt on the top of the left hand guide rod before proceeding.

1. Send the platen on the down stroke and allow the pins to go in. Carefully watch for the point when the control valve lever is about to be actuated into the up position and stop the lever in the "natural" neutral position, with your hand **held above** the control lever.
2. Check the backlash between the bellcranks and the bin, and if incorrect, adjust the return bolt on top of the right hand guide rod carefully $\frac{1}{2}$ a turn at a time, (up to decrease clearance or down to increase clearance).
3. Repeat the cycle until the correct backlash is achieved.
4. Tighten locknut securely.
5. After setting right bank of pins, repeat procedure for left hand bank of pins using adjustment bolt on left hand guide rod. Ensure the hexagonal sides of the bolt are kept parallel with the side of the guide rod when adjustment is complete.

Note: Take care to adjust small amounts then cycle the press each time to prevent over-adjustment and possible damage to guide rods.

12.10 Unpinning clearance

The retraction of the baling pins is a crucial part of the press's operation. The pins are retracted by the unpinning posts, which are welded to the platen, pulling down on the rocker arm pawls, which are in between the top cross members.

To enable the baling pins to be fully retracted from the wool, the posts must remain in contact with the pawls until the baling pins are fully retracted.

This length of contact or "travelling purchase" can only be achieved by having the gap between both components as close as possible once they have separated.

No less than 0mm and no more than 2mm.

If this gap is too excessive due to wear on the pawls or distortion of the platen, the unpinning posts will lose contact with the pawls prematurely, leaving the baling pins partially in the bin while the wool is being pressed, possibly resulting in damage to the press or woolpack.

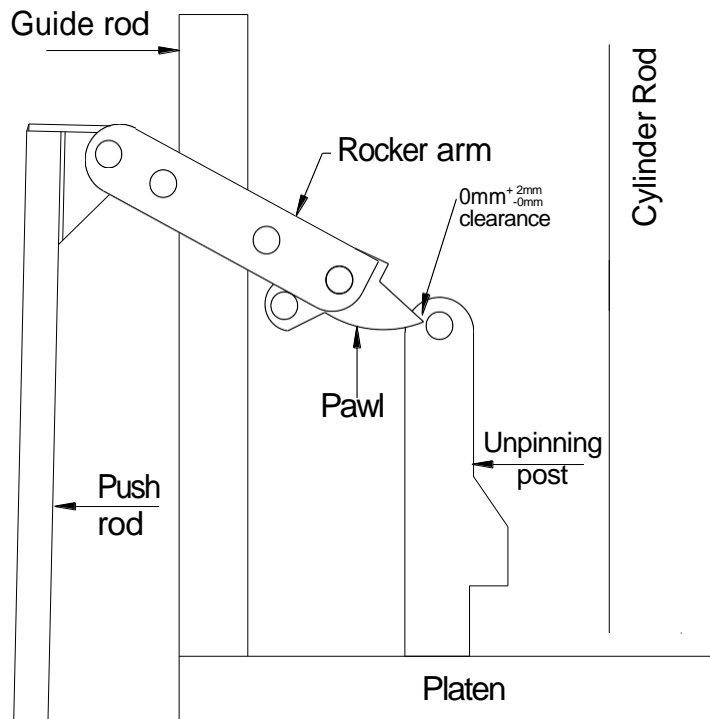

Unpinning clearance illustration

12.11 Hydraulic pump operation

The Nachi PVS-IB-22 Pump is a variable displacement piston pump with a pressure compensator valve.

The pump produces a flow of 30 lts/min (7 gpm) until pressure builds to 5000 Kpa (750 psi).

This opens the pressure compensator valve and reduces the flow to approximately 7-9 lts/min (1.5-2.0 gpm, second stage)

When the changeover to the second stage happens, you should notice a change in sound and speed, and a reduction in load on the motor.

The compensator valve adjustment controls the pressure at which the changeover cycle takes place. 5000 kpa (750psi)

Before adjusting any settings it is advisable to measure and note the stand out distance of the screw. Screw adjustments in to increase, out to decrease.

12.12 Pump adjustment procedure

1. Low pressure adjustment screw (compensator valve). This controls the pump changeover from 1st to 2nd stage. (Approximately 140 to 150 kilos of wool), It also governs how fast the platen returns. Voltage drop may be experienced in some sheds. This may cause the motor to labour around the changeover stage or on the return stroke. A small adjustment of the Low Pressure screw will cure both problems in most cases.

2. High pressure adjustment lock nuts (minimum stop) the positioning of this setting determines the flow once the press is in the second stage.

Adjustments of the lock nuts clockwise will increase the flow rate but also increases the power demand.

Anti clockwise will decrease the flow rate.

This adjustment is only needed if the press is stalling or labouring in the second stage but rarely has to be reset and should be done with a flow meter and tong tester.

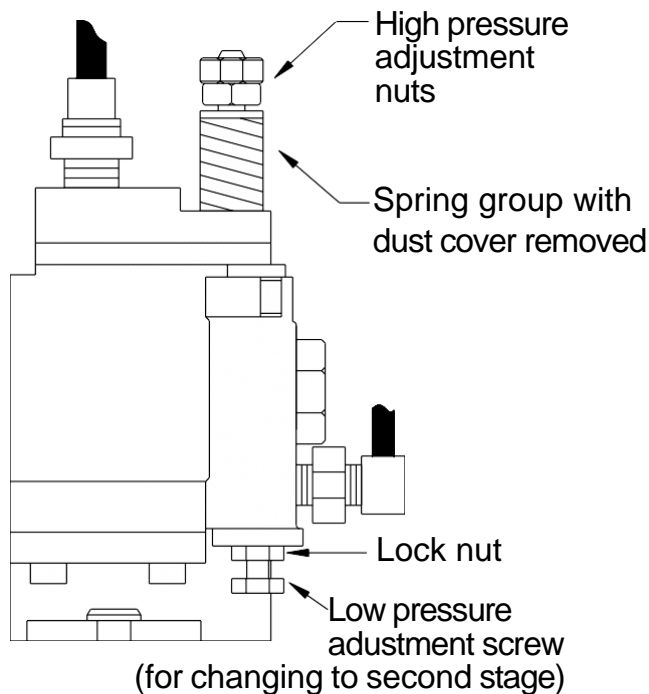

Hydraulic pump adjustment illustration

Troubleshooting**All items marked * see adjustment procedure***Note: For all electrical faults qualified persons only may undertake fault finding & repairs.**Note: For all hydraulic faults qualified persons only should undertake fault finding & repairs.*

Problem	Possible cause	Action
The motor will not start	Fuses blown Faulty plug Start capacitor is burnt out Supply voltage is too low	Check reason and replace. Replace Replace Correct supply
Starter switch chatters and will not engage	Supply voltage is too low Extension cord is too long or too light Overload not set Faulty switch	Correct supply. 20 Amp extension cord. Leave for one minute then press red stop button to reset Contact Electrician
Motor stalls	Overload Second stage on pump not activated Second stage flow capacity too high Pressure relief valve set too high Coupling loose Pump seized	Check power supply Check low pressure adjustment (compensator) on pump* Page 17 Adjust high pressure (minimum stop) adjustment* Page 17 Reset pressure relief valve Tighten or replace Replace pump
Press will not operate	No oil flow 3 phase motor running in reverse	Check operation of electric motor pump, control valve, coupling, ram and oil level Electrician to reverse phases to suit.
Pump noise	Cavitation (air in system) Loose coupling Faulty pump	Check oil level Check suction hose Check oil filter damaged, loose or clogged Check for damage, wear, alignment and secure key and grub screws Replace
Control valve noisy	Relief valve incorrect Spool valve travel incorrect Valve not neutralising	Check for damage and reset pressure relief valve Check detent Check handle for damage Adjust Check linkage is not bent.

Press is too slow	Loose detent on valve Pump worn out (Check with flowmeter) High pressure adjustment (minimum stop) screwed out Seals worn or damaged on ram piston	Remove dust cover on bottom of valve spool and tighten detent <i>Note: do not dismantle the deten</i> Replace pump Re-adjust* Page 17 Replace or repair
Motor labours once cycle is complete	Control valve return bolt setting incorrect	Reset as per instructions* Page 11
Control valve handle vibrates once cycle is completed	As above	As above
Cannot press heavy weights	Pressure relief set below 2600 psi Pump not coming in on second stage Seals worn or damaged on ram piston Voltage supply too low overloads should cut out	Check using pressure gauge and reset Check low pressure adjustment* Page 17 Replace or repair Check your local supply current.
Baling pins bent down	Press cycle not completed Clearance between pawls and unpinning post excessive	Replace bale pins. Operate as per instructions Check for wear or misalignment Repair or replace and adjust as per diagram* Page 12
Baling pins will not hold bale	Pins bent (as above)	Replace pins
Baling pins do not go in fully	Guide rods out of adjustment	Adjust correctly* Page 11
Baling pins will not fully retract	Clearance between pawls and unpinning post excessive Build up of wool around bellcrank	Check for wear or misalignment Repair or replace and adjust as per diagram* Page 12 Remove pinning guard and remove wool

GENERAL LAYOUT

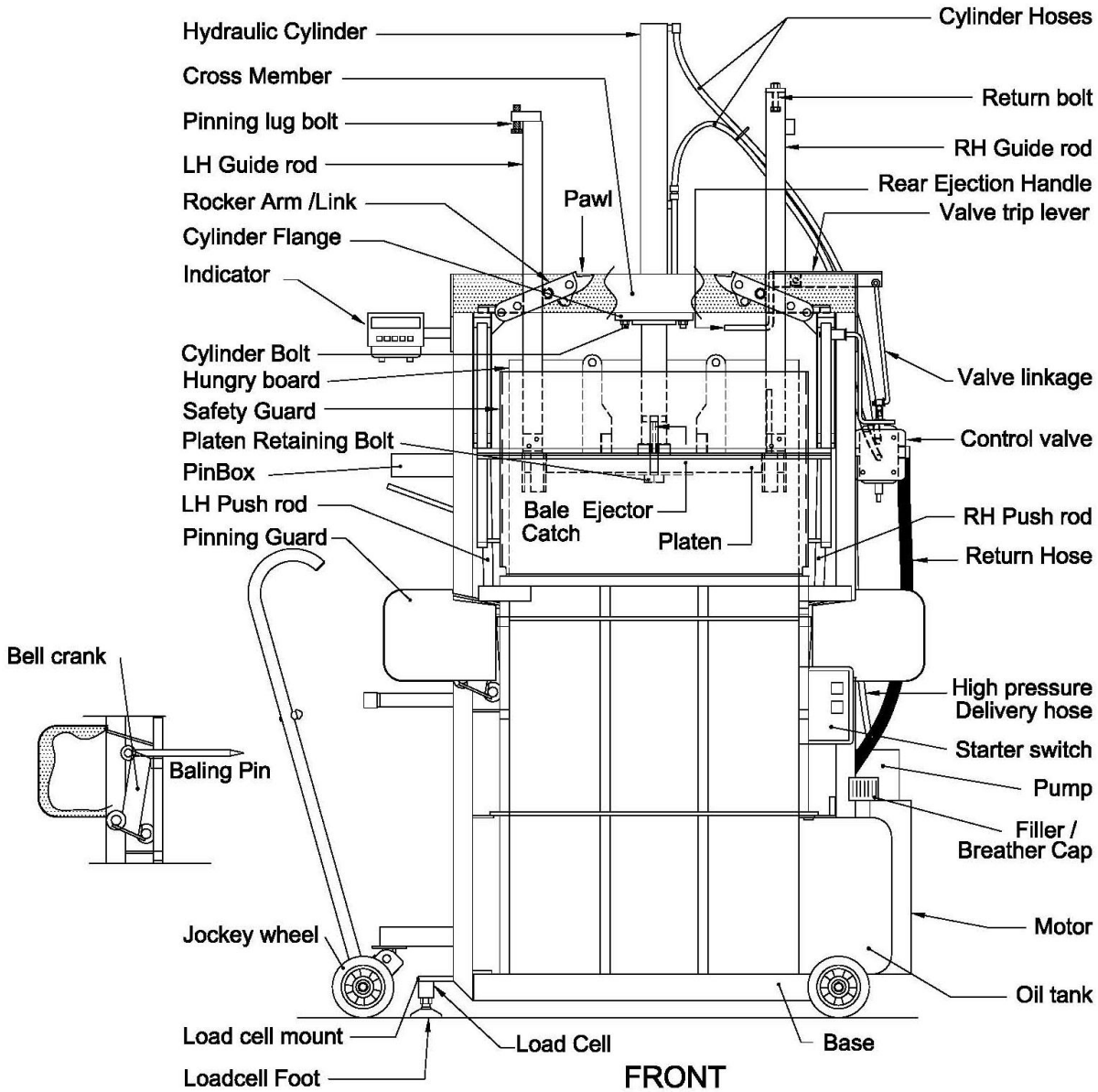

15 Side view

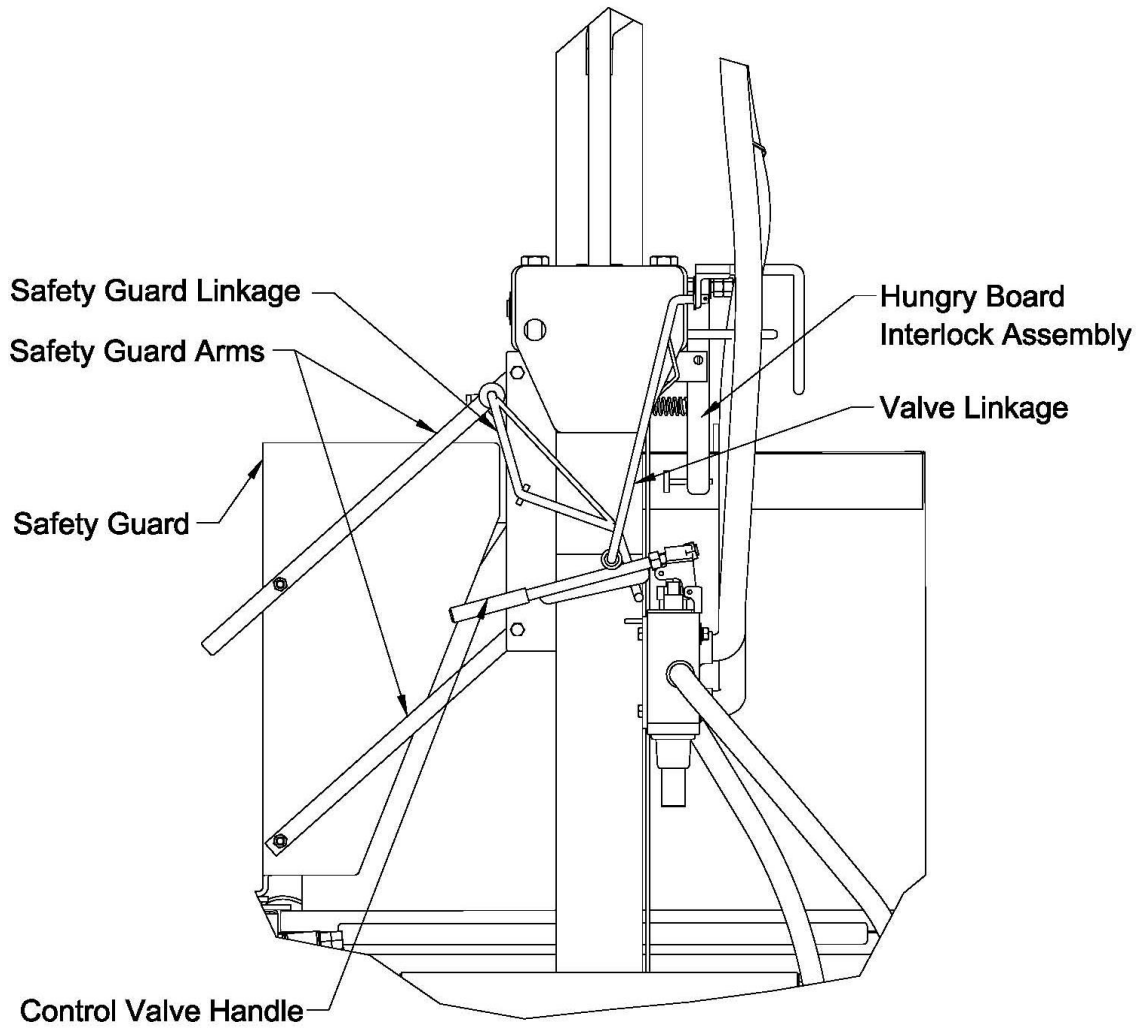

LUBRICATION POINTS

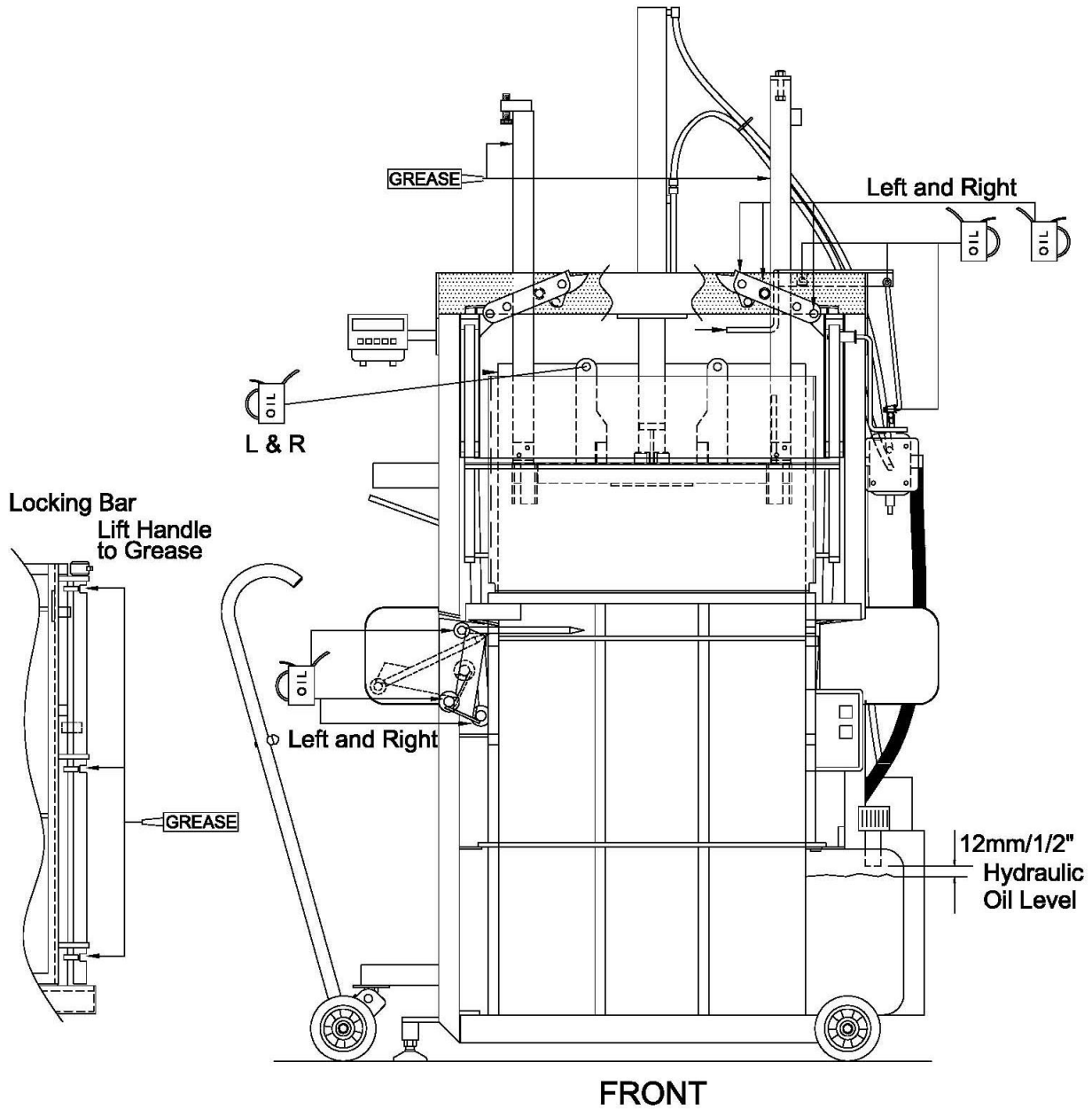

FX1+

INDICATOR

The brand new FX1+ indicator features audible and visible alarms that let you know when you're approaching target weight and built-in memory to retain the last weight reading in the case of a power failure.

- Numbers on the readout flash faster while approaching the target weight
- Intermittent buzzer gets faster as the target weight is approached
- Continuous buzzer sounds when the target weight is reached

The FX1+ also has two additional modes when used with the optional Iconix load bars. Use **FREE** mode for weighing static loads such as produce, and use **HOLD** mode for livestock weighing which averages the weight of the animal and displays this until the next animal is weighed.

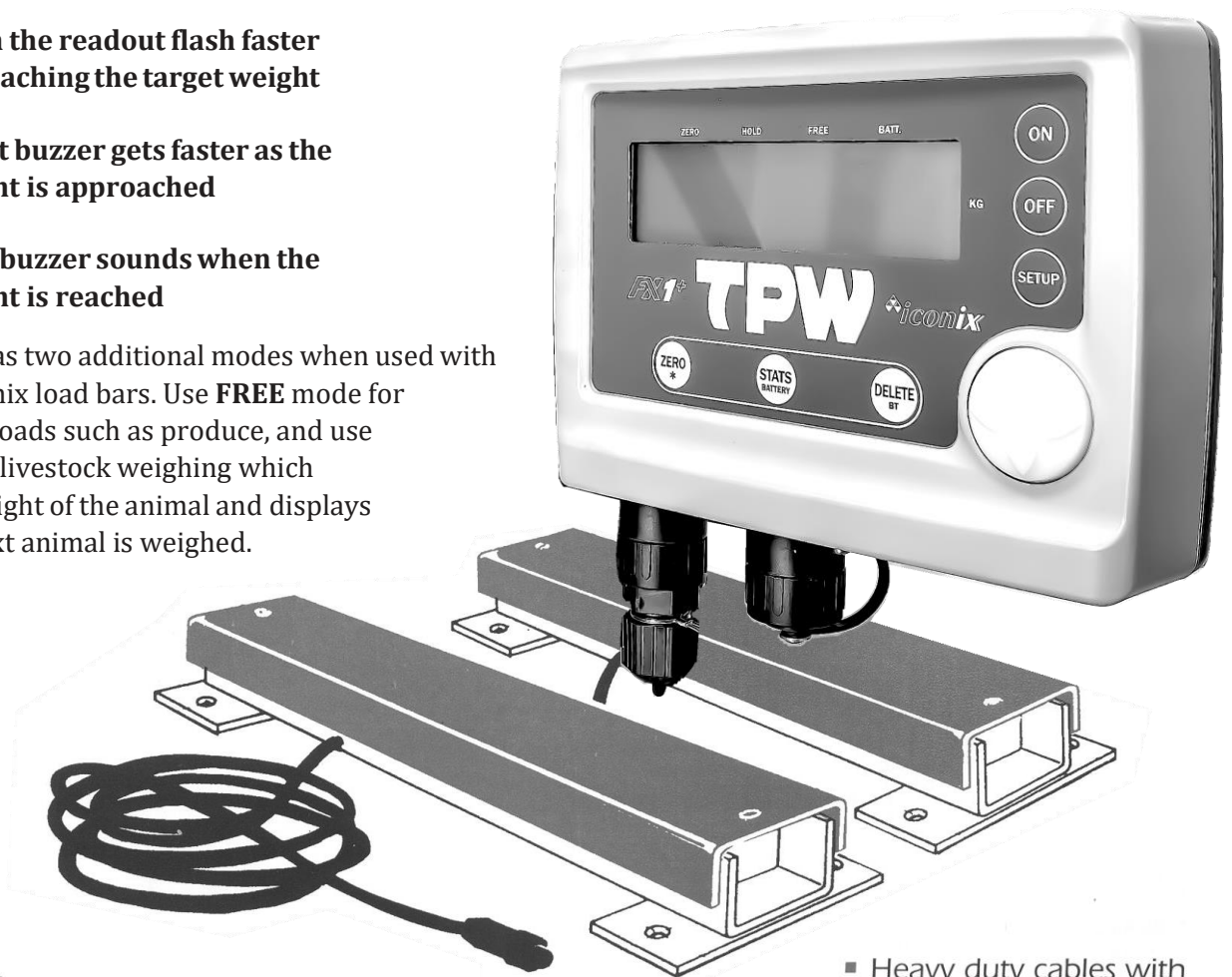

- Auto zero
- Zero tracking
- Tough polycarbonate, weatherproofed indicator case
- 12 volt DC
- Optional AC adaptor
- Reverse battery protection fitted
- Auto 'low voltage' shut down
- Low battery indicator
- Weighs up to 2000kg

- Heavy duty cables with amphenol connectors
- Tough waterproofed and rust protected steel loadbars
 - Loadbars available in two lengths, 600mm and 1000mm
- Loadbars compatible with all FX indicators
- Optional 'heavy duty' loadbars to weigh up to 3000kg



iconix

EXCELLENCE IN ELECTRONIC WEIGHING

FX1+ INDICATOR

SIMPLICITY IN ELECTRONIC WEIGHING

The FX1 Electronic Weighing System comprises an electronic indicator display unit, two precision matched steel load bars, battery cables and a convenient race bracket.



OPERATIONAL SPECIFICATIONS

- Supply voltage:
 - Nominal 12 Volt DC
 - Minimum 10 Volt DC
 - Maximum 18 Volt DC
 - Reverse battery protection fitted
 - Supply Current:
 - Nominal 95mA
 - Low Battery Indicator:
 - Illuminates at 11.3 Volts
 - Indicator shuts down at 10 Volts
 - Scale Base Selection
 - The indicator automatically recognises the scale
 - 2000kg loadbar set
 - 300kg single clip-together platform
 - 1000kg dual clip-together platform
 - 3000kg heavy duty loadbar set.
 - Resolution
 - The indicator 'Auto Ranges' in graduated steps, from zero to full scale capacity. The ranges for the 2000kg loadbar set are:
 - 0-20kg 100 gram steps
 - 20-50kg 200 gram steps
 - 50-200kg 500 gram steps
 - 200-500kg 1kg steps
 - 500-2000kg 2kg steps
 - Zero Tracking:
 - Small residual weights left on the scale between weighings (dust and dirt build-up) are automatically "Zero tracked" out. Zero indicator ▲ shows that the scale has been restored to zero between weighings. A press of the 'ON/ZERO' key resets the scale to zero if 'Zero Tracking' has not been achieved.
 - Accuracy:
 - ± 1%
 - Temperature Range:
 - 5 C to +50°C
- AVAILABLE FROM:

MECHANICAL SPECIFICATIONS

- INDICATOR:
 - Case Material:
 - Tough polycarbonate alloy material.
- Loadbar Connectors:
 - Quality Amphenol series plugs.
- Battery Connector:
 - Heavy duty 'Canon' connector.

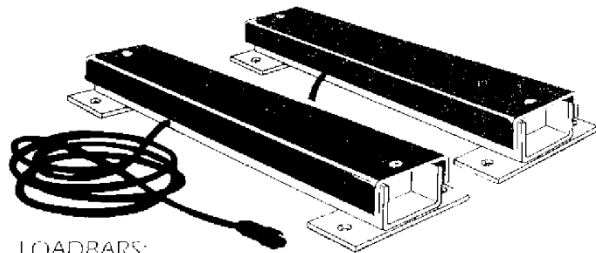

LOADBARS:

- Cables:
 - Heavy duty 6 metre PVC cables.
- Connectors:
 - Quality Amphenol series plugs.
- Chassis:
 - LOWER – heavy duty galvanised steel
 - UPPER – electroplated steel, powder coated to 113/11/F1 specification
- Capacity:
 - 2000kg (pair)
- Lengths:
 - 600mm or 1000mm
- Height:
 - 100mm
- Mounting Holes:
 - To fit 12mm bolts

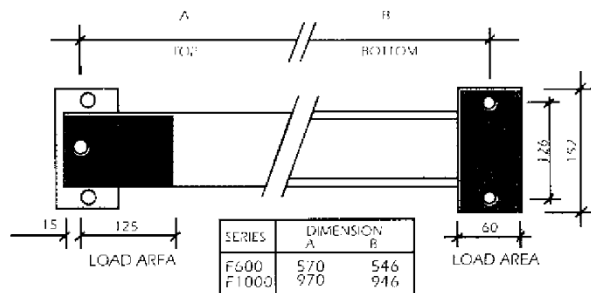

EXCELLENCE IN ELECTRONIC WEIGHING



WARRANTY REGISTRATION

TPW WOOLPRESS

Retain this section

Serial number:

Delivery date:

Selling agent:

Address:

Telephone:

Model & Start switch:

Aussie Xpress

Kiwi Xpress

240V Soft Start

240V DOL

480V DOL

415V DOL

For full guarantee conditions see the owner's manual.
Return the tear off section of this card completed
within seven days of purchase to effect warranty
period.

Return this section to:

HEINIGER Australia
5A Tayet Link
Bibra Lake, WA 6163

Or

HEINIGER New Zealand
1B Chinook Place
Hornby, Christchurch NZ

Serial number:

Delivery date:

Purchased by:

Address:

Telephone:

Email:

Selling agent:

Address:

Telephone:

Model & Start switch:

Aussie Xpress

Kiwi Xpress

240V Soft Start

240V DOL

480V DOL

415V DOL